

INTRODUCTION

The OX-SB-170 model is a Modular Spreader Beam from the OX & RUD Spreader Beam range. It is capable of lifting configurations of up to 170t (170,000 kg) in different lengths and angles configurations of the upper branches that will be described below. The Working Load Limit should never be exceeded or used in an unintended lifting configuration.

ASSEMBLY

It is made up of different elements that can be assembled using screwed flanges to form a specific length, finishes at the ends by a set of End Unit + Drop Link at each end with intermediate sections assembled in the central part.

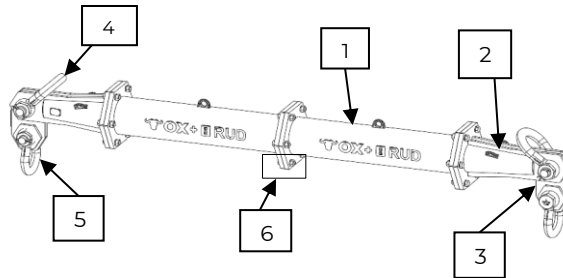

Configuration with standard OX-SB Sections
Certified by DNV
 DNV-ST-0378 · DNV-ST-0377

COMPONENT TABLE OX-SB-170					
Part	Code	Description	Nominal Length [mm]	Dimensions L x W x H [mm]	Weight [kg]
1	80220170SXXX	OX-SB-170 Section XXXX mm	XXXX (A)	XXXX x 617 x 537	111,9 + 0,0978xL[mm]
	80220170S050	OX-SB-170 Section 500mm	500	500 x 617 x 537	160,8
	80220170S100	OX-SB-170 Section 1000mm	1000	1000 x 617 x 537	209,7
	80220170S200	OX-SB-170 Section 2000mm	2000	2000 x 617 x 537	307,4
	80220170S300	OX-SB-170 Section 3000mm	3000	3000 x 617 x 537	405,2
	80220170S400	OX-SB-170 Section 4000mm	4000	4000 x 617 x 537	503
	80220170S500	OX-SB-170 Section 5000mm	5000	5000 x 617 x 537	600,7
80220170S600	OX-SB-170 Section 6000mm	6000	6000 x 617 x 537	698,5	
2	80220170E	OX-SB-170 End Unit 1000mm	1000	1171 x 617 x 537	305,8
3	80220170D	OX-SB-170 Drop Link	310	342 x 115 x 610	94
4		120t - 3 1/2" Bow Shackle safety pin (top) (B)	Variable (D)	3 1/2"	-
5		85t - 3" Bow Shackle safety pin (bottom) (B)	Variable (D)	3"	-
6		SCREWS 14399 HV HOT DIP GALV. - 10.9 (C)	-	M20 x 90	-



(A) APPROVED NOMINAL LENGTH BETWEEN 500 AND 6000 mm.
 (B) OX & RUD RECOMMENDS LYRE-TYPE SHACKLES WITH THREADED PIN WITH NUT AND SAFETY PIN (OR WIDE-BODY SHACKLE WHEN INDICATED). CONSIDER THE LOSS OF CAPACITY (BENDING LOSS) BETWEEN THE SLINGS AND THE SHACKLES, EVEN IF THEY ARE WIDE-BODY SHACKLES, WHEN DIMENSIONING THE SLINGS.
 (C) SCREW TIGHTENING TORQUE: 180 NM. NEVER EXCEED THIS TIGHTENING TORQUE. SPANNER SIZE 32MM.
 (D) VARIABLE LENGTH DEPENDING ON THE BRAND AND MODEL USED.

GENERAL CONDITIONS

- The longest sections should be placed in the center of the set.
- A maximum of 6 intermediate sections can be placed for each set (without considering the End Units).**
- If telescopic sections are used (not DNV certified), up to 2 can be mounted, replacing 2 sections each. That is, up to 2 telescopic sections plus 2 conventional sections.
- The lower slings can work up to a maximum of 6° from the vertical in both directions.
- Check that there is always space between the end of the sling and the End Unit. (Clearance)
- Leave space between the Spreader Beam and the load.

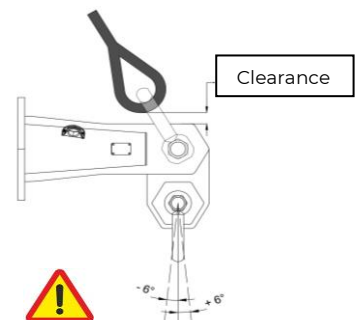

BOLTING TIGHTENING SEQUENCE

The joints must be tightened evenly and progressively in three complete cycles following the sequence shown in the image below. Each cycle should be tightened to 30%, 60% and 100% of the specified tightening torque of 180Nm.

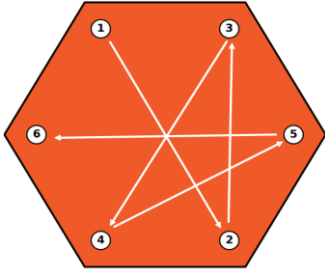

BOLT TIGHTENING CYCLE	1st CYCLE	2nd CYCLE	3rd CYCLE
TIGHTENING TORQUE	55Nm	110Nm	180Nm

MATERIAL AND FINISH

The device is constructed from welded structural steel, sandblasted and painted in accordance with ISO 12944 category C2 or other finishes on request.

LIMITS OF USE

TEMPERATURE

The elements of the OX Spreader Beams OX-SB-170 range defined in this Technical Specification Sheet can be used in **a temperature range between -20°C and 80°C**, as they have been dimensioned and validated within this range.



Please consult our sales team for use in an extended temperature range, both above and below. Upon request, we can issue a certificate for a different temperature range with the capacity adjusted to the new conditions.

CLASSES OF WORKING CYCLES

The products in the OX-SB Spreader Beam range are designed to withstand $\leq 16,000$ load cycles, which corresponds to type U0 for total number of working cycles in accordance with standard EN 13155:2020 + A1:2025.

Exceptionally, it is possible to increase the number of permissible load cycles by issuing a Fatigue Calculation Report, which analyses the actual operating conditions, such as:

- Effective load magnitude and operating range.
- Lifting frequency and estimated number of annual cycles.
- Required and/or expected service life of the equipment.
- Type of lifting equipment used (crane, hoist, etc.).
- Dynamic conditions present during operation (impacts, speeds, angles of inclination, accelerations).
- Working environmental conditions (temperature, humidity, corrosive agents).
- Required level of reliability and availability.
- FEM service class, if available or can be estimated.



Please consult our sales team if a Fatigue Calculation Report is required. To assess the feasibility of the study, please complete the data collection form provided. The cost of preparing the Fatigue Calculation Report is not included in the product price; therefore, if required, it will be quoted separately.

LENGTHS, ANGLES AND LOST HEIGHT

The maximum capacity of the spreader beam varies depending on the length of the assembly and the working angle of the top slings. The top slings are designed to operate at **angles ranging from 20° to 45° relative to the vertical, with no additional tolerance**. In the case of intermediate angles, the capacity must be adjusted to the capacity indicated for the immediately more restrictive angle; that is, between 20° and 30°, the limit capacity will be that of 30°, and between 30° and 45°, the limit capacity will be that of 45°. Formulas are provided for determining the dimensions for the typical configurations of 20°, 30° and 45° relative to the vertical. The table below shows the dimensions for whole lengths in metres.

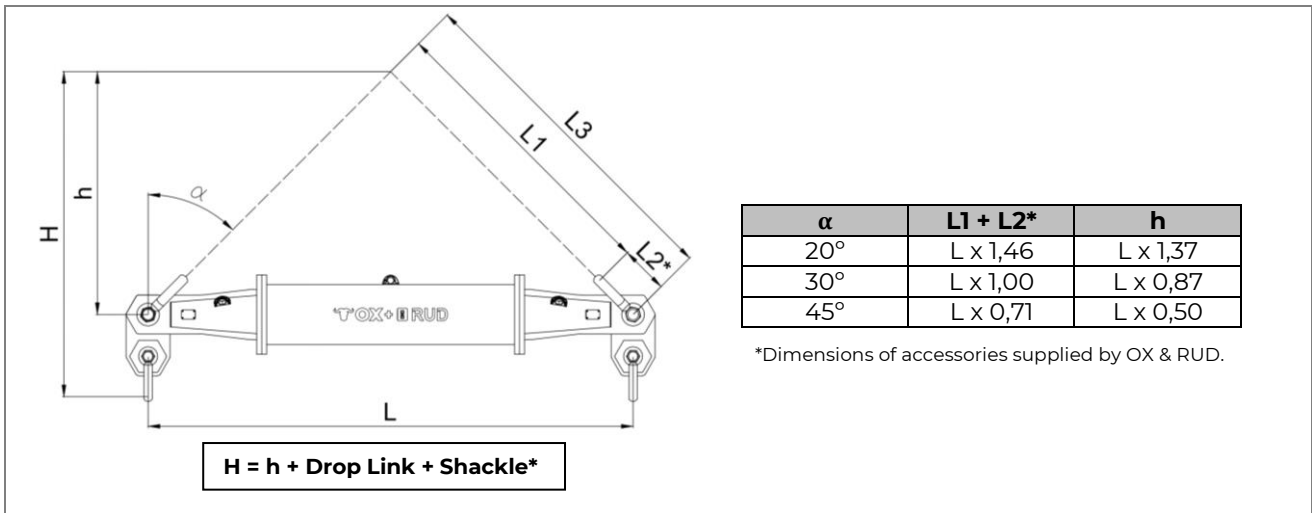

LOAD TABLE ACCORDING TO ANGLE AND LENGTH AND RECOMMENDED CONFIGURATIONS

L (m)		2	3	4	5	6	7	8	9	10	11	12	13	14	15	16	17	18	19	20	21	22	23	24
$\alpha=20^\circ$	W.L.L. (t)	170	170	170	170	170	170	170	170	170	170	170	170	170	170	170	170	170	170	170	150	140	120	108
	L1 (m)	2,5	4	5,5	6,9	8,4	9,8	11,3	12,8	14,2	15,7	17,1	18,6	20,1	21,5	23	24,4	25,9	27,4	28,8	30,3	31,7	33,2	34,7
	h (m)	2,8	4,2	5,5	6,9	8,3	9,6	11	12,4	13,7	15,1	16,5	17,9	19,2	20,6	22	23,3	24,7	26,1	27,4	28,8	30,2	31,6	32,9
	H (m)	3,5	4,9	6,2	7,6	9	10,3	11,7	13,1	14,4	15,8	17,2	18,6	19,9	21,3	22,7	24	25,4	26,8	28,1	29,5	30,9	32,3	33,6
$\alpha=30^\circ$	W.L.L. (t)	170	170	170	170	170	170	170	170	170	170	170	170	170	170	152	134	120	107	95	84	75	68	
	L1 (m)	1,6	2,6	3,6	4,6	5,6	6,6	7,6	8,6	9,6	10,6	11,6	12,6	13,6	14,6	15,6	16,6	17,6	18,6	19,6	20,6	21,6	22,6	23,6
	h (m)	1,8	2,7	3,5	4,4	5,3	6,1	7	7,9	8,7	9,6	10,5	11,4	12,2	13,1	14	14,8	15,7	16,6	17,4	18,3	19,2	20,1	20,9
	H (m)	2,5	3,4	4,2	5,1	6	6,8	7,7	8,6	9,4	10,3	11,2	12,1	12,9	13,8	14,7	15,5	16,4	17,3	18,1	19	19,9	20,8	21,6
$\alpha=45^\circ$	W.L.L. (t)	170	170	170	170	170	170	170	170	170	170	162	144	128	112	100	88	78	70	62	55	49	44	40
	L1 (m)	1	1,8	2,5	3,2	3,9	4,6	5,3	6	6,7	7,4	8,1	8,9	9,6	10,3	11	11,7	12,4	13,1	13,8	14,5	15,2	16	16,7
	h (m)	1	1,5	2	2,5	3	3,5	4	4,5	5	5,5	6	6,5	7	7,5	8	8,5	9	9,5	10	10,5	11	11,5	12
	H (m)	1,7	2,2	2,7	3,2	3,7	4,2	4,7	5,2	5,7	6,2	6,7	7,2	7,7	8,2	8,7	9,2	9,7	10,2	10,7	11,2	11,7	12,2	12,7
Recommended Configuration "EU + Section + EU" *EU includes (End Unit + Drop Link) =1m	EU	EU	EU	EU	EU	EU	EU	EU	EU	EU	EU	EU	EU	EU	EU	EU	EU	EU	EU	EU	EU	EU	EU	EU
	EU	1	2	2	4	4	4	2	4	4	4	2	4	4	4	2	4	4	4	2	4	4	4	4
	-	EU	EU	1	EU	1	2	4	4	4	4	4	4	4	4	4	4	4	4	4	4	4	4	4
	-	-	-	EU	-	EU	EU	1	EU	1	2	4	4	4	4	4	4	4	4	4	4	4	4	4
	-	-	-	-	-	-	-	EU	-	EU	EU	1	EU	1	2	4	4	4	4	4	4	4	4	4
	-	-	-	-	-	-	-	-	-	-	-	EU	-	EU	EU	1	EU	1	2	4	4	4	4	4
	-	-	-	-	-	-	-	-	-	-	-	-	-	-	-	EU	-	EU	EU	1	EU	1	2	4
	-	-	-	-	-	-	-	-	-	-	-	-	-	-	-	-	-	-	-	-	EU	-	EU	EU

The dimensions with accessories are considered the accessories indicated in the table and supplied by OX & RUD.