



OX SPREADER BEAM FRAME RANGE CU OX-SB V3

USE AND MAINTENANCE MANUAL



DOCUMENT	USE AND MAINTENANCE MANUAL
VERSION	0 – Revision
DATE	08/10/2025
ISSUED BY	J.G.A.
VALIDATED	C.S.M.

TABLE OF CONTENTS

PREVIOUS INFORMATION.....	3
DEFINITIONS.....	3
GENERAL CONCEPTS OF LIFTING LOADS.....	5
GENERAL FEATURES	6
TRANSPORTING AND STORAGE.....	7
SAFETY.....	8
ASSEMBLY.....	9
USAGE.....	11
MAINTENANCE.....	16
CLEANING.....	16
WARRANTY.....	16
INSPECTIONS.....	18
NOTES.....	22

ANNEXES

TECHNICAL DATASHEET OF SUPPLIED PRODUCTS

DECLARATION OF CONFORMITY OF SUPPLIED PRODUCTS

PREVIOUS INFORMATION

The goal of this manual is to provide the necessary information for the correct and safe use and maintenance of the OX Spreader Beam Frame. This product is made up of 4 units of Corner Units CU OX-SB V3 (not DNV certified) combined with modular sections OX-SB V2 and/or telescopic sections OX-SBT V2 (not DNV certified), to form a square or rectangular structure. The size of the square or rectangle can be modified by combining different modular sections of the OX-SB V2 and/or adjusting the length of the OX-SBT V2 telescopic sections.

This Use and Maintenance Manual is part of the equipment supplied and must be kept in perfect conditions during the equipment's life of use. It must be kept in an accessible and protected place near the place of use of the equipment, being always available for possible consultation. In case of deterioration of the manual, the user must request a new one. The manufacturer undertakes to supply a new one as soon as possible.

In the event of sale or transfer to a third party, this manual must always be delivered together with the equipment and it is recommended that the name of the new owner be communicated to the manufacturer.

This manual is directed and intended for production and maintenance personnel, occupational risk prevention technicians and, in general, all operators who will manipulate this device. It is mandatory to read this manual carefully before using the device and strictly adhere to all the instructions contained in this manual for the correct and safe use of the device.

The manufacturer declines all responsibility for damages caused to people and other equipment in the following cases:

- Incorrect use or negligence.
- Use by personnel without training of this equipment.
- Use contrary to and in disagreement with current safety regulations.
- Electrical power defects.
- Serious failures in the planned maintenance.
- Modifications not authorized in writing.
- Intervention of unauthorized personnel.
- Use of non-original spare parts and components.
- Total or partial failure to comply with the instructions described in this manual.
- Failure to carry out the proper maintenance operations in accordance with this manual and record them in the attached intervention sheet.
- Events, disasters, exceptional events, and accidents not attributable to the operation of the machine.

Although the main features of the unit described in the manual do not change, OX & RUD reserves the right to modify, without prior notice, features and accessories that may improve the performance of the unit.

The data indicated in this manual belongs to OX & RUD. Reproduction in whole or in part without the authorization of OX & RUD is strictly prohibited.

DEFINITIONS

MANUFACTURER:

Responsible for the design and construction of the device according to current regulations, as well as for certifying the characteristics of the device and determining the conditions of use expressed in this manual.

USER:

It is the organization that uses the equipment, whether owned, assigned or rented, and that is responsible for its correct use in accordance with what is specified in this manual, as well as the regulations in relation to risk prevention and safety in the work environment in the place and at the time in which they are carried out. To do this, it will designate a person in charge trained in that function.

RESPONSIBLE:

Designated by the user, he must ensure that this manual is available to the operators of the spreader beam and that they have read and fully understood the instructions in this manual. He must also provide training for the correct use of the equipment and carry out the training evaluation for each type of operation to be carried out, whether it is use, assembly, maintenance, repairs, etc.

OPERATOR:

He is responsible for developing the tasks of assembly and use of the device, as well as the maintenance, cleaning, repair and transport of the equipment. With the purpose of developing them in an efficient and safe way. His/her training will be evaluated by the person in charge designated by the User, who will be the final responsible for any incident.

LIFTING CONFIGURATION (ASSEMBLY):

Set of parameters that determine the specific characteristics of a given lifting process. On the one hand, the maximum capacity is determined by the OX Spreader Beam Frame model. On the other hand, there is a reduction in capacity depending on the length between the lower hooks, as well as the angle formed by the top slings. See **CU OX-SB V3 Product Technical Data Sheet** (Annex I).

GENERAL CONCEPTS OF LIFTING LOADS

In order to correctly lift loads using lifting elements such as lifting beams, spreader beams (and others) and complementary accessories, a series of basic concepts must be taken into consideration, which must be understood and respected in order to ensure that the lifting of loads is carried out in a safe way.

WORKING LOAD LIMIT (W.L.L.):

The W.L.L. (Working Load Limit) is the maximum working load for which the lifting beam is designed for normal use. Never exceed this limit.

WEIGHT OF LOAD TO BE LIFTED:

Before lifting a load, take into account not only the weight of the load, but also the weight of the accessories involved in lifting the load (lifting beam and accessories). And always consider the capacity of each part as independent, considering the load below each part. Example: on the image below, there are 4 top slings, they need to be calculated for all the items below them. The top shackles, same thing, all the items below + the load, needs to be calculated.

Thus, for a lifting configuration using a spreader beam frame together with accessories, it must be observed that the maximum weight of the load to be lifted must always be less than or equal to the total capacity of the spreader beam frame (W.L.L.) minus the weight of the spreader beam frame and lifting accessories.

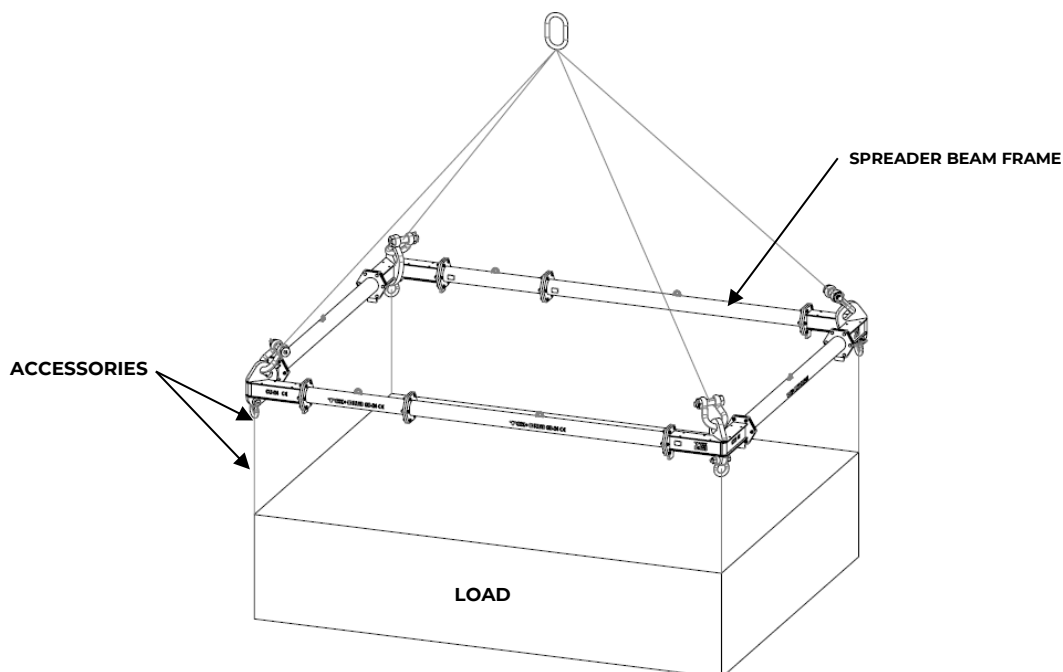

$$\text{Weight}_{\text{LOAD}} \leq (\text{WLL}_{\text{SPREADER BEAM FRAME}} - \text{Weight}_{\text{SPREADER BEAM FRAME}} - \text{Weight}_{\text{ACCESSORIES}})$$

**IMPORTANT NOTES**

- NOTE 1: The load capacity of the spreader beam frame must be reduced by the tare weight of the complete lifting assembly, considering the weight of all the accessories, including the weight of the spreader beam frame itself.
- NOTE 2: The maximum weight of the load to be lifted by the lifting assembly must always be less than or equal to the W.L.L. of the spreader beam frame, deducting also the weight of the spreader beam frame itself and the weight of the lifting accessories.
- NOTE 3: There can be a reduction in the total capacity due to the own weight of the spreader and the rigging used during the lift (shackles, grommet slings, round sling, etc.), needs to be calculated by the customer every different lifting configuration.
- NOTE 4: For all the accessories on top of a lifting beam, spreader beam... the maximum capacity of that accessories must be evaluated for each specific lifting configuration (since the longer the beam the greater its weight).

GENERAL FEATURES

DESCRIPTION:

The purpose of the OX Spreader Beam Frame is to manipulate and lift loads safely, using modular elements that can be assembled to achieve the desired length. The maximum authorized load depends on the model and the lifting configuration applied, which determines the length and working angle of the top slings, see the **CU OX-SB V3 Product Technical Data Sheet** (Annex I).

MATERIAL & FINISHING:

The device is made of welded structural steel, blasted and painted according to ISO 12944 category C2 or other finishes upon request.

IDENTIFICATION:

Each of the individual elements that make up an OX spreader beam has an identification plate describing the Spreader Beam model, the Logo and the OX brand, as well as a characteristics plate specifying model, serial number, the working load limit*, tare and year of manufacture.



*The plate indicates **SEE MANUAL** in the W.L.L. section. (Working Load Limit) since the maximum capacity is restricted depending on the load configuration applied, that is, the maximum capacity of the Spreader varies depending on the length of the Spreader and the working angle of the slings. For more details see **CU OX-SB V3 Product Technical Data Sheet** (Annex I).

Additionally, the sections have adhesive vinyl (Usually in black, other colors upon express request) identifying the model, brand, and OX & RUD logo, as well as the CE mark.

TRANSPORTING AND STORAGE

When leaving the factory, the device is usually supplied disassembled (unless otherwise expressly indicated) in a stable position and duly packaged and protected in units that can be handled by crane and, preferably, it must be transported in vehicles or containers with removable roofs and unloaded by crane.

If individual manipulations are carried out using a crane, the individual parts should preferably be grabbed by the hook points provided for lifting that allow them to be manipulated in a horizontal position. For other maneuvers such as turning (tilting), always use textile slings to avoid chafing and damaging the surface finish of the components.

The individual components of the OX Spreader Beam Frame with a tare weight of more than 25kg have specific lifting points to facilitate assembly by crane. These lifting points are for handling only, never for loading.

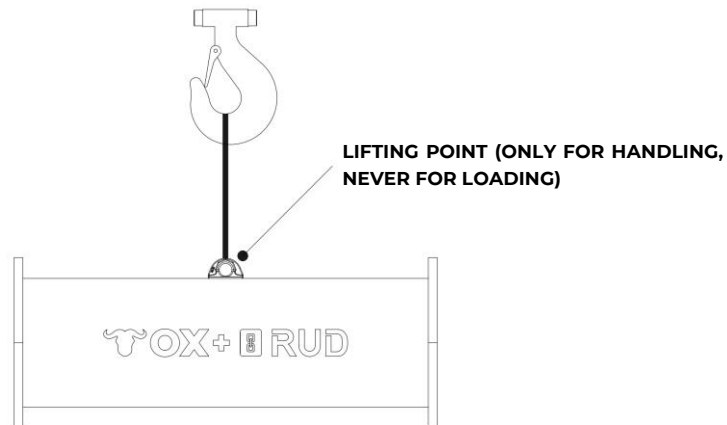

SAFETY









The device has been designed to be used in safe conditions to prevent or minimize possible risks, through correct use and regular maintenance.

The device must be used and maintained only by qualified personnel by the Person Responsible designated by the company that uses the product.

The operating instruments (push-button/crane remote control) should only be used by qualified personnel.

The operating space around and especially under the device and the load to be handled must be free of obstacles and properly illuminated, as well as the entire perimeter of access to said area delimited for people.

If the safety conditions are not met, the operation must be interrupted immediately, the load safely placed on the ground as soon as possible and the pertinent corrections made, or the maneuver canceled if it is not available.

	<p>Mandatory use of safety helmet. Fall from a height of loose parts such as crane screws, accessories, tools or even the load itself or its packaging.</p>		<p>Danger suspended load. Never stand under the load or around the operation.</p>
	<p>Mandatory use of safety footwear. Entrapment of feet or falling loose parts.</p>		<p>Danger of entrapment with mechanical elements. Do not get between moving or adjustable elements.</p>
	<p>Mandatory use of safety gloves. Possibility of cuts or abrasions when handling parts and accessories</p>		<p>Crushing hazard. Do not get between the load or tools and the floor, ceiling or sides.</p>
	<p>Obligation to read manual before handling equipment. Possibility of putting oneself in danger due to lack of knowledge of the equipment.</p>		<p>Undetermined danger. Pay special attention to the indications preceded by this symbol in this manual</p>

ASSEMBLY

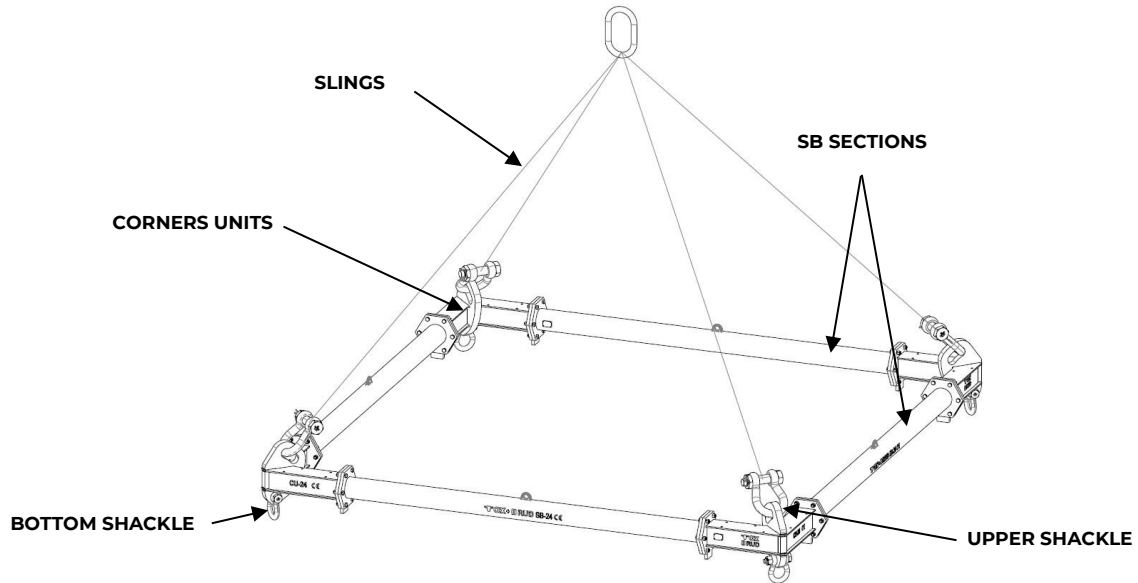

For more information, see the **Technical Datasheet CU OX-SB V3** (Annex I).

COMPOSITION WITH CORNER UNITS + SPREADING BEAMS

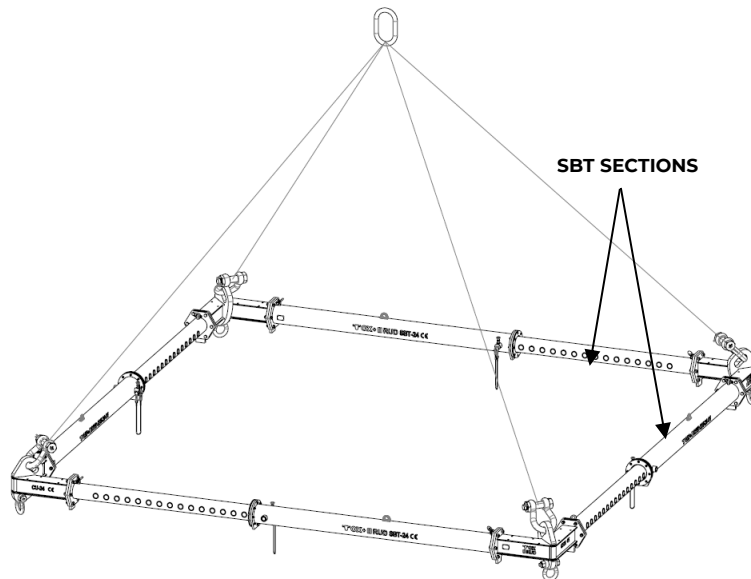

For more information, see the **Technical Datasheet CU OX-SB V3** (Annex I).

COMPOSITION WITH CORNER UNITS + TELESCOPIC SPREADER BEAMS

1. Determine that the required lifting configuration is compatible with the OX Spreader Beam Frame model and determine the combination of elements necessary to make the composition.
2. Validate the availability of the elements to form the necessary length.



IMPORTANT NOTES

- NOTE 1: The length of the Spreader must be such that the bottom slings do not deviate from the vertical by more than 6°. If necessary, the bottom accessories (slings) must be lengthened to meet this requirement.
 - NOTE 2: The lengths of the top slings must be equal to or greater than the calculation length to guarantee the working angles.
3. Inspect each element separately: Welds, deformations, and general condition of the element.
 4. Place the horizontal and aligned elements in the relative position that they will occupy in the configuration on the ground or on stands and join the elements with the appropriate screws, first with a small tightening and then applying the tightening torque applied in star mode.



IMPORTANT NOTES

- NOTE 1: The longest sections must be placed in the center of the set.
- NOTE 2: A maximum of 6 intermediate sections can be placed for each set (without considering the End Units).
- NOTE 3: If telescopic sections are used (not DNV certified), up to 2 can be mounted, replacing 2 sections each. That is, up to 2 telescopic sections plus 2 conventional sections.



Check the **CU OX-SB V3 Product Technical Data Sheet (Annex I)** for the measurements, quality, tightening torque of the screws and the wrench necessary to carry out the procedure. Follow all instructions and recommendations specified in the document. (Detail image of typical star tightening for 6 screws).

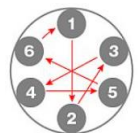

5. Assemble the top slings on the top shackles (those with the highest capacity).



Respect the measurements of the top slings, in capacity and length, defined for each model according to the load, the working angle and the total length of the assembly, defined in the **CU OX-SB V3 Product Technical Data Sheet (Annex I)**.

6. Position the sling, grommet or chain with the upper shackle (highest capacity) and close the shackle by placing the threaded pin, nut and safety pin to prevent any eventual loosening of the nut.
7. Repeat the process from step 3 for the top slings of all Corner Units in the set.
8. Assemble the accessories of the bottom slings on the bottom shackles (those with the smallest load capacity).

9. Place the bottom shackle (with the sling, grommet, or chain ring) matching the pin hole with the lower hole of the Corner Unit and place the threaded pin, nut, and safety pin of the nut to prevent eventual loosening.
10. Repeat the process from step 8 for the top slings of all Corner Units in the set.
11. Join the free ends of the top slings with the hook that will move the assembly (crane hook). And join the free ends of the bottom slings with the load to be moved.

USAGE

PREVIOUS TASKS

Before performing any maneuver, the following must be checked

- The device: Following the checklist in the "Maintenance" section of this manual.
- The load to be handled: Check the good condition and correct dimensioning of the load attachment points, paying attention to the search for cracks, fissures, deformations, or damage. You should not lift or transport a load that does not have the appropriate attachment points provided and in good condition.
- Lifting accessories: Check all the accessories that will be involved in the maneuver (crane hook, slings, shackles, etc.) to verify that they are correctly sized and in proper condition for use.

CARGO HANDLING

TEMPERATURE:

The entire range of OX Spreader Beams can be used in the range of capacities determined in the **CU OX-SB V3 Product Technical Data Sheet (Annex I)** in a **temperature range between -20°C to 80°C**, since it has been sized and validated within this range.



Consult our sales team for use in an extended temperature range, both above and below. On express request we can issue a certificate for a different temperature range with the capacity adjusted to the new conditions.

ACCESSORIES:

The Spreader Beam assembly must be lifted with the lifting accessories (slings, grommets, chains, etc.) with the length determined by the chosen load configuration, with the accessories of the capacity and type that also adjust to the measurements, shapes and direction of work of the crane hook, whether single or double or other, always with safety latches, without twisting or bending of the accessories, nor overlapping of elements or tensions of any kind between them.

If this is not possible, they should consider the incorporation of an intermediate element or modify the coupling configuration or the type of accessory until these conditions are met, as well as other conditions indicated in the instructions of the manufacturers of such accessories or in the regulations applicable in each case.



Consult our sales team for the supply of accessories suitable for your specific needs.

You can also consult our sales team about the cost of advice and preparation of a personalized Rigging Plan.

GENERAL CONSIDERATIONS:

The load must be lifted correctly in compliance with all safety regulations and in such a way that the center of gravity of the load is centered with the crane hook. In addition, the load must be completely horizontal. If this is not the case, the load must be repositioned.



Under no circumstances should the equipment be used for lifting people, dragging loads, or transporting loads of greater tonnage than it is approved for.



The load may only hang from the lower terminals located on the Corner Units, in no case from any other part of this spreader beam. In some cases, the same load can be lifted with several cranes or with a cascade configuration (several levels), using the OX Spreader Beam Frame with OX Spreader Beams.

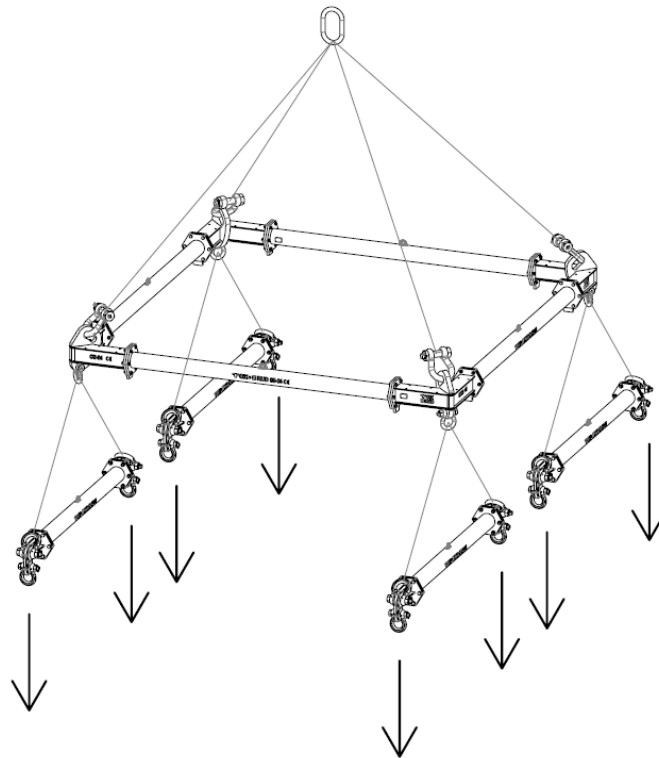

COMPOSITION FOR LOAD LIFTING WITH 8 ANCHORAGE POINTS.



In the case of lifting with multiple cranes or cascade configurations, the weight distribution must be calculated to guarantee that no element of the configuration receives a load greater than the nominal capacity.



Consult our sales team about any application that you do not know how to solve or that requires additional solutions out of range.

LIFTING CONFIGURATION (ASSEMBLY):



IMPORTANT NOTES

- The maximum capacity can be determined using a table that takes into account the length and working angle, check the **CU OX-SB V3 Product Technical Data Sheet (Annex I)** to verify the capacities of a specific model. Under no circumstances is it permitted to work at angles greater than 45° from the vertical.

Upper angle: max. 45°

The upper slings of the Spreader Beam Frame, work at a maximum of 45° from the vertical.

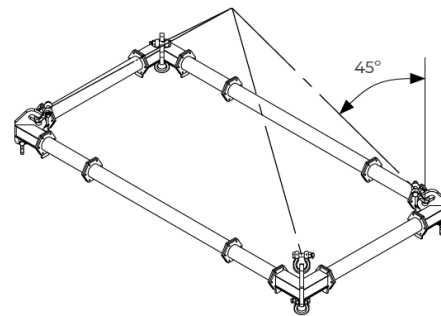

- The **bottom slings** may not deviate +/- 6° from the vertical or what is equivalent to 96°/84° with respect to the axis of the spreader.

Bottom angle: max. ± 6°

The bottom slings of the Spreader Beam Frame work at a maximum of +/-6° from the vertical.

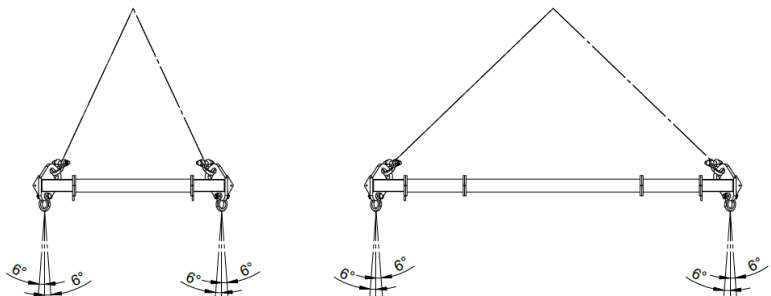

3. **The spreader beam when loaded can tilt up to 6° and as long as the bottom slings descend perpendicular to the axis of the spreader** (The combined inclination must not exceed 6°). If the **lower branches descend slightly inclined, the inclination will have to be deducted** from the value of 6°.

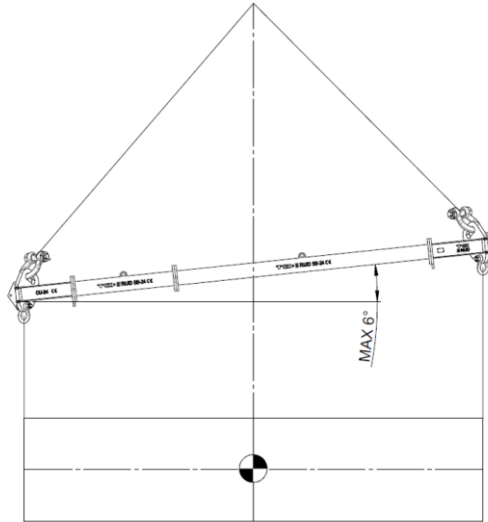

4. The center of mass or center of gravity of the load must be aligned with the crane hook, being able to lift off-center loads horizontally, but always with the load beam in a horizontal position or slightly inclined as indicated in point 3.
5. **The empty spreader beam** may need to be inclined in particular cases such as in asymmetrical lifting configurations, in which case an **inclination of up to 12° is allowed, but the lower branches must be provided with an additional length** to avoid touching the load with the spreader beam.

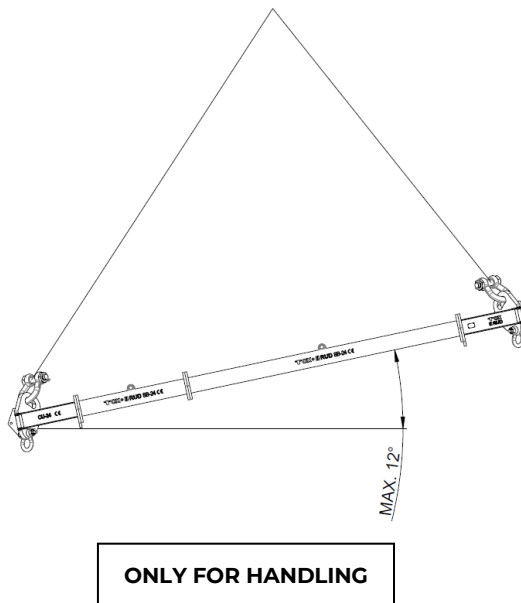

6. If necessary, a counterweight can be inserted on one side between the lifting accessories, or a special counterweighted version **can be supplied from the factory so as not to exceed the inclination of 12°**.
7. In the case of handling loads with an offset center of gravity, the **spreader is used asymmetrically**, i.e. the terminals on both sides receive different loads. In this case, the described working angles may not be exceeded, and the spreader may not be used with the maximum rated load. The load on the individual terminals must be calculated according to the lever law: $Length\ right\ side \times Load\ right = Length\ left\ side \times Load\ left$, whereby the total load is the sum of both sides. The result of the highest load must not exceed half the rated load of the model in any case or the angle of the lifting configuration or even the section model must be changed. The calculation is required for both longitudinal axes of the spreader beam frame.

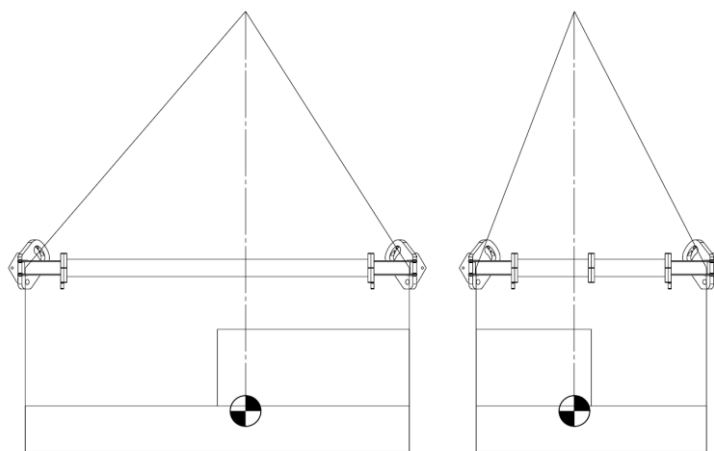

Asymmetric loads (offset center of gravity)

8. It is very important to **maintain a clearance between the sling and the end unit**, as well as to leave space between the modular spreader beam arm and the load, since under load they can suffer elastic deformation and reach and rub against each other, crush or even collapse the hoist.

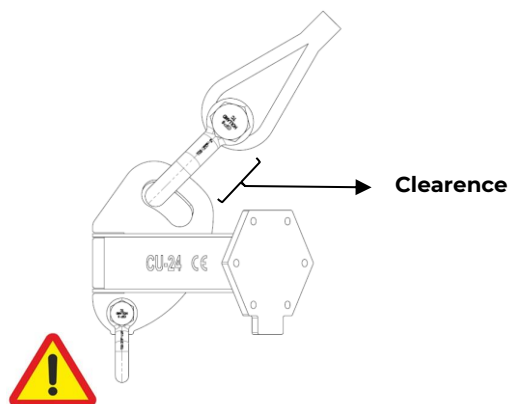

WORKING LOAD LIMIT:

Check the **CU OX-SB V3 Product Technical Data Sheet** (Annex I) for information about the capabilities of a specific model.

MAINTENANCE

Qualified personnel must check the condition of the components and bolted joints, as well as the lifting accessories. The inspection status of the crane must also be checked, as well as that the entire lifting procedure is carried out in accordance with the Health and Safety Protection Regulations in the place where the maneuver is to be performed.

<i>CHECKLIST</i>		Before each use	Monthly	Annual	Other
CRANE	1.0. VALIDATE THE CAPACITY AND CONFIGURATION OF THE CRANE TO LIFT THE LOAD PLUS THE TARE OF THE LIFTING SET WITH THE REQUIRED RADIUS ACCORDING TO THE LIFTING PLAN.	X			
	1.1. TO VALIDATE THE INSPECTION STATUS OF THE CRANE IN GENERAL AND THE LOAD LIMITER IN PARTICULAR.			X	
	1.2. VISUALLY VALIDATE THE CONDITION OF THE CRANE HOOK, ITS SWIVELING AND TILTING CAPACITY AND ITS SAFETY LATCH.	X			
SPREADER BEAM	2.0. VISUALLY CHECK THAT THE WELDED JOINTS ARE FREE OF CRACKS* AND THE ELEMENTS ARE FREE OF DEFORMATIONS.	X			
	2.1. CHECK THAT THE END UNITS AND DROP LINKS ARE FREE OF DEFORMATION* WITH BURRS AND THAT THEY SWING FREELY WITHIN THE WORKING RANGE ONCE THE SHACKLES ARE ASSEMBLED.	X			
	2.2. EACH TIME A SECTION IS ASSEMBLED, CHECK THE TIGHTENING TORQUE OF ALL BOLTS AS THEY ARE ASSEMBLED, WE RECOMMEND A TORQUE WRENCH TRIP, CALIBRATE IT TO THE REQUIRED TORQUE AND THE TRIP CHECKS THE TORQUE**.				EVERY TIME AN ELEMENT IS MOUNTED
	2.3. IF IT IS STORED ASSEMBLED. AT EACH OPERATION CHECK THE TIGHTENING TORQUE WITH A TORQUE WRENCH OF A DIFFERENT BOLT IN EACH SECTION, IF ANY OF THEM IS FOUND TO BE LOOSE, CHECK ALL OF THEM.	X			
ACCESSORIES	3.0. CHECK THAT THE SHACKLES ARE OF THE SIZE INDICATED IN THE COMPATIBILITY TABLE ACCORDING TO MODEL AND ARE WITHIN THE REQUIRED CAPACITY IN THE CASE OF USING A DIMENSIONALLY COMPATIBLE MODEL, BUT OF DIFFERENT CAPACITY.	X			
	3.1. CHECK THAT THE CAPACITY AND LENGTHS OF THE LIFTING ACCESSORIES ARE WITHIN THE REQUIREMENTS OF THE LOAD CONFIGURATION TO BE PERFORMED.	X			
	3.2. INSPECTION OF LIFTING ACCESSORIES IN ACCORDANCE WITH CURRENT REGULATIONS IN THE REGION OF USE***: SHACKLES TEXTILE SLINGS WIRE ROPE SLINGS GRUMMETS CHAIN SLINGS AND ACCESSORIES OTHERS			X	

*If cracks appear, perform weld inspection to determine the extent. Block use until repair and favorable re-inspection.

**If red or white rust appears on the metal fittings, they should be replaced with new ones.

***If you provide us with a list of accessories and region of use, we can prepare Specific Technical Instructions for you. Please consult our sales team.

Block use until repair and re-inspection with favorable results.

CLEANING

Keep the equipment and its accessories clean of excess grease, oil, and dirt in general to be able to properly evaluate the conditions of use of the lifting equipment and accessories.

WARRANTY

This OX & RUD product has a 12-month warranty from the date of delivery, subject to separate written notifications or agreements. The warranty covers material or manufacturing defects, once it has been verified that work has not been carried out under abnormal circumstances.

For warranty claims, it is the customer's responsibility to prepare a technical report specifying the lifting configuration performed in the manoeuvre (a Rigging Plan is necessary). The lifting configuration must be described, documenting the lifting with pictures with date of each lift, to ensure that the lifting was done correctly or not.



We guarantee the replacement of spare parts or the repair of elements by our assistance service in our workshops. The customer must send the parts to be repaired, postage paid to OX & RUD Sant Boi - Barcelona and once repaired, OX & RUD will also send them, if they are within the warranty, free of charge nationwide (Spain).

We do not guarantee compensation for possible damages, direct or indirect, to tools, machinery or people, caused by said unit. We have civil liability insurance.

EXCLUDED FROM THIS WARRANTY

- Breakdowns caused by improper use.
- Breakdowns caused by modifications and spare parts not indicated by OX & RUD.
- Damage caused by lack of maintenance (see maintenance book).
- Improper installation and start-up.
- Damage caused in transportation.
- Use in corrosive environments, acids, steam, etc.
- Use of equipment / items manufactured by other companies (for example: the use of another manufacturer)

EXPIRATION OF WARRANTY

The unit will be exempt from the particularities of the warranty in the following cases:

- In case of late payment or breach of contract.
- In case of repairs or modifications without express authorization from OX & RUD.
- When there is damage caused by incorrect use.
- For reasons that do not derive from a normal work operation.
- All disputes will be settled in the courts of Barcelona (Spain).

INSPECTIONS

Periodic inspections should be carried out with the frequency and intensity indicated by the national regulations applicable in the country where the equipment is to be used, but they should all indicate the measures necessary to ensure that work equipment subjected to influences that may cause deterioration that could lead to hazardous situations is subject to periodic checks and, where appropriate, tests, in order to ensure compliance with the safety and health provisions and to remedy such deterioration in good time. Likewise, additional checks must be carried out on such equipment whenever exceptional events occur, such as transformations, accidents, natural phenomena or prolonged lack of use, which could have detrimental consequences for safety. They should also indicate that such checks should be carried out **by competent personnel** and that the results of the checks should be documented, made **available to the labor authority** in each country and retained for the useful life of the equipment.

When the goods leave the manufacturer's or distributor's warehouse, a first label is affixed to the equipment, stating that the equipment has been inspected in a specific month and year as the date of commissioning of the equipment. See example of a label in case the equipment has been overhauled and shipped in February 2025:

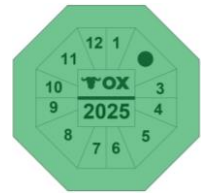

Once the equipment is at the customer's home, the customer will be responsible for having it checked by competent personnel and for keeping a record of these checks, carried out according to the regulations of the place where the equipment is used and according to the periods established in the **Maintenance Sheet of this OPERATION AND MAINTENANCE MANUAL.**



Ask our sales team or distributor network about the existence of a Service Center in your region to service this equipment as well as the lifting accessories.

INSPECTION FORMAT

SHEET N.º ____ of ____

DATE PUT INTO SERVICE:		REVISION DATE:	
------------------------	--	----------------	--

CHECKLIST		WHEN	RESULT OK / NOT OK or n/a	OBSERVATIONS:
CRANE	1.0. VALIDATE THE CAPACITY AND CONFIGURATION OF THE CRANE TO LIFT THE LOAD PLUS THE TARE OF THE LIFTING SET WITH THE REQUIRED RADIUS ACCORDING TO THE LIFTING PLAN.	Before each use		
	1.1. TO VALIDATE THE INSPECTION STATUS OF THE CRANE IN GENERAL AND THE LOAD LIMITER IN PARTICULAR.	Annual		
	1.2. VISUALLY VALIDATE THE CONDITION OF THE CRANE HOOK, ITS SWIVELING AND TILTING CAPACITY AND ITS SAFETY LATCH.	Before each use		
SPREADER BEAM	2.0. VISUALLY CHECK THAT THE WELDED JOINTS ARE FREE OF CRACKS* AND THE ELEMENTS ARE FREE OF DEFORMATIONS.	Before each use		
	2.1. CHECK THAT THE END UNITS AND DROP LINKS ARE FREE OF DEFORMATION* WITH BURRS AND THAT THEY SWING FREELY WITHIN THE WORKING RANGE ONCE THE SHACKLES ARE ASSEMBLED.	Before each use		
	2.2. EACH TIME A SECTION IS ASSEMBLED, CHECK THE TIGHTENING TORQUE OF ALL BOLTS AS THEY ARE ASSEMBLED, WE RECOMMEND A TORQUE WRENCH TRIP, CALIBRATE IT TO THE REQUIRED TORQUE AND THE TRIP CHECKS THE TORQUE.	Every time any element is assembled		
	2.3. IF IT IS STORED ASSEMBLED. AT EACH OPERATION CHECK THE TIGHTENING TORQUE WITH A TORQUE WRENCH OF A DIFFERENT BOLT IN EACH SECTION, IF ANY OF THEM IS FOUND TO BE LOOSE, CHECK ALL OF THEM.	Before each use		
ACCESSORIES	3.0. CHECK THAT THE SHACKLES ARE OF THE SIZE INDICATED IN THE COMPATIBILITY TABLE ACCORDING TO MODEL AND ARE WITHIN THE REQUIRED CAPACITY IN THE CASE OF USING A DIMENSIONALLY COMPATIBLE MODEL, BUT OF DIFFERENT CAPACITY.	Before each use		
	3.1. CHECK THAT THE CAPACITY AND LENGTHS OF THE LIFTING ACCESSORIES ARE WITHIN THE REQUIREMENTS OF THE LOAD CONFIGURATION TO BE PERFORMED.	Before each use		
	3.2. INSPECTION OF LIFTING ACCESSORIES IN ACCORDANCE WITH CURRENT REGULATIONS IN THE REGION OF USE***: SHACKLES TEXTILE SLINGS WIRE ROPE SLINGS GRUMMETS CHAIN SLINGS AND ACCESSORIES OTHERS	Annual		
	OVERALL RESULT OF THE INSPECTION:			
NAME:	COMPANY:			DATE:

*If cracks appear, perform weld inspection to determine the extent. Block use until repair and favorable re-inspection.

**If red or white rust appears on the metal fittings, they should be replaced with new ones.

***If you provide us with a list of accessories and region of use, we can prepare Specific Technical Instructions for you. Please consult our sales team. Block use until repair and re-inspection with favorable results.

YOU MAY COPY THIS PAGE FOR ADDITIONAL REVISION SHEETS.

INSPECTION RECORD FORMAT

HOJA N.º

FECHA VENTA	
-------------	--

FECHA REVISIÓN:	
EMPRESA:	
RESULTADO:	
OBSERVACIONES:	

FECHA REVISIÓN:	
EMPRESA:	
RESULTADO:	
OBSERVACIONES:	

FECHA REVISIÓN:	
EMPRESA:	
RESULTADO:	
OBSERVACIONES:	

FECHA REVISIÓN:	
EMPRESA:	
RESULTADO:	
OBSERVACIONES:	

FECHA REVISIÓN:	
EMPRESA:	
RESULTADO:	
OBSERVACIONES:	

PUEDE COPIAR ESTA PÁGINA PARA OTRAS HOJAS DE REGISTRO DE REVISIONES.

INSPECTION RECORD FORMAT

HOJA N.º

FECHA VENTA	
-------------	--

FECHA REVISIÓN:	
EMPRESA:	
RESULTADO:	
OBSERVACIONES:	

FECHA REVISIÓN:	
EMPRESA:	
RESULTADO:	
OBSERVACIONES:	

FECHA REVISIÓN:	
EMPRESA:	
RESULTADO:	
OBSERVACIONES:	

FECHA REVISIÓN:	
EMPRESA:	
RESULTADO:	
OBSERVACIONES:	

FECHA REVISIÓN:	
EMPRESA:	
RESULTADO:	
OBSERVACIONES:	

PUEDE COPIAR ESTA PÁGINA PARA OTRAS HOJAS DE REGISTRO DE REVISIONES.

HEAVY LIFTING EQUIPMENT

PATENT PENDING
NEW
PATENT PENDING

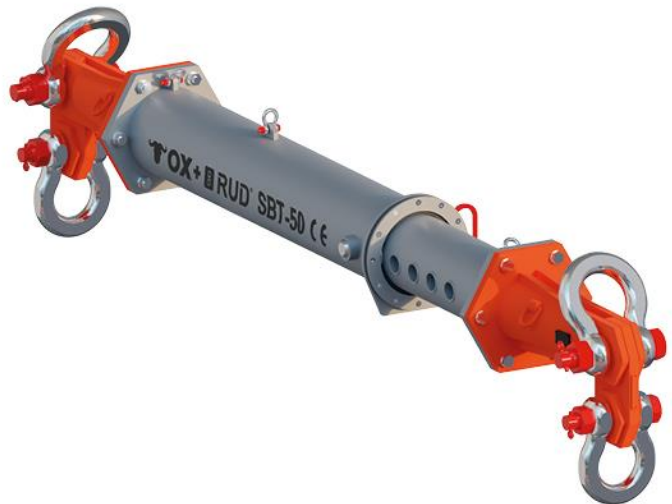
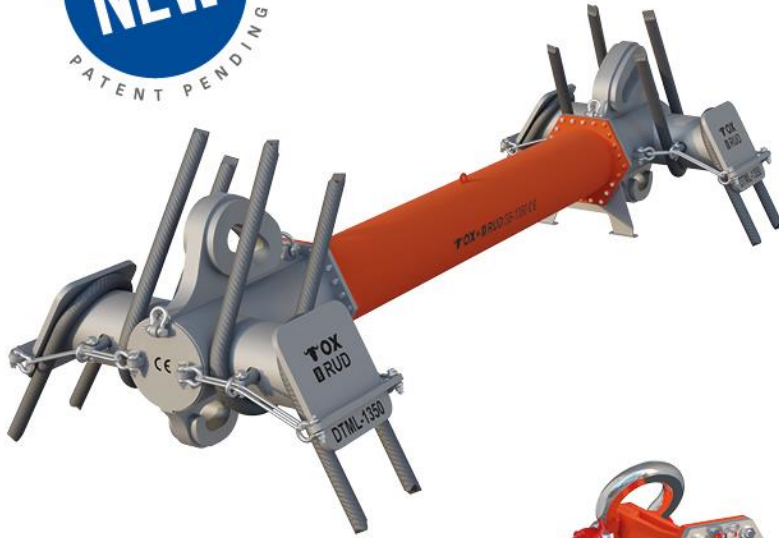

**YOUR TRUSTED
PARTNER FOR
HEAVY LIFTING
SOLUTIONS**

 **OX+ RUD**
LIFTING SOLUTIONS

Mare de Déu de Núria, 4
08830 Sant Boi de Llobregat
Barcelona · Spain

Tel. +34 931 358 928
info@ox-rud.com
ox-rud.com

ANNEXES

TECHNICAL DATASHEET OF SUPPLIED PRODUCTS
DECLARATION OF CONFORMITY OF SUPPLIED PRODUCTS

