

# HEAVY LIFTING EQUIPMENT

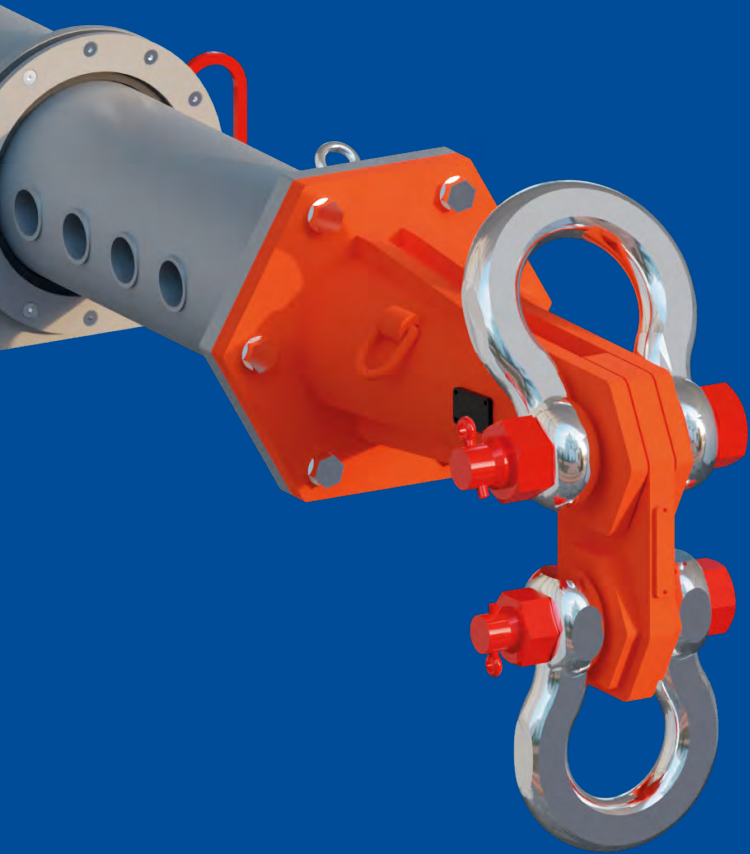

Take a look and  
discover our  
newest solutions

Spreader Beams  
 Lifting Beams  
 Adjustable Lifting Beams  
 Adjustable H Beam  
 Multi-lug Beams  
 Telescopic Spreader Beams  
 Container Spreader  
 Swivel Lifting Beams  
 Self Propelled Trolleys  
 Rotating Trolleys  
 Tilting Coil Tong  
 C-Hooks



**YOUR TRUSTED  
PARTNER FOR  
HEAVY LIFTING  
SOLUTIONS**

NEW EQUIPMENT

# WE ARE GOING TO SURPRISE YOU!



## TELESCOPIC SPREADER BEAMS

The one and only!  
The first MODULAR & TELESCOPIC in Europe. The telescopic struts can be used in combination with our standard struts and end-units, keeping the same working load limits and working lengths. **From 9 to 110 t.**

To modify the length with a normal spreader you need between 30 minutes to 1 hour, with our new SBT you only need 2 minutes...  
Use it and you'll love it!

## MINIFORCE30 SELF-PROPELLED TROLLEY

Our newest and beloved MINIFORCE30, with a super-reduced height, **30 t capacity**, with many other features:

- Dual mode: use it with batteries or change to single-phase 230v in one second (plugged & unplugged).
- Easy to replace Lithium batteries.
- The only one with OX-TOUCH SCREEN, connected with Wi-Fi for technical service abroad, inspections, software upgrades... And much more!

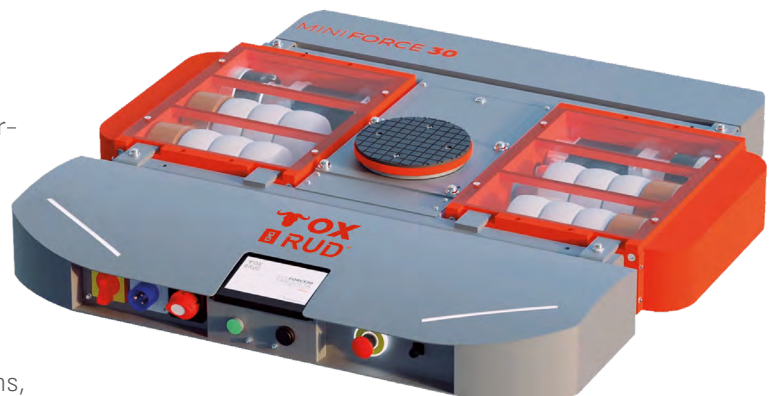

# WHAT'S NEW?

**OX & RUD**, always working on new heavy lifting and moving equipment to help you out.

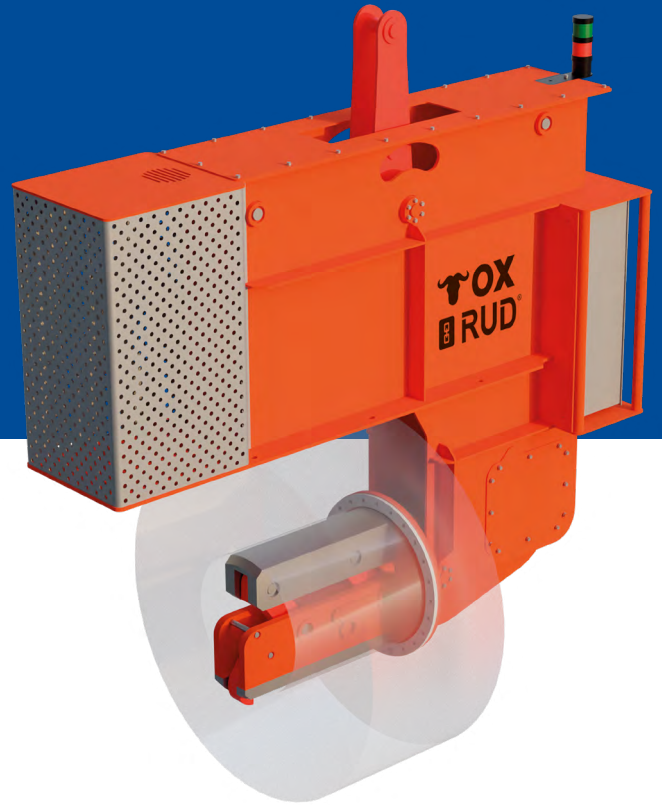

## TILTING COIL TONG

Do you need to lift & tilt your coil in a minute? Easy & quick positioning of the hydraulic clamp. Put your coil in vertical or horizontal with no worries about the security. With the new OX-SELF BALANCING SYSTEM, and controlled by the same overhead crane control or via radio remote control.

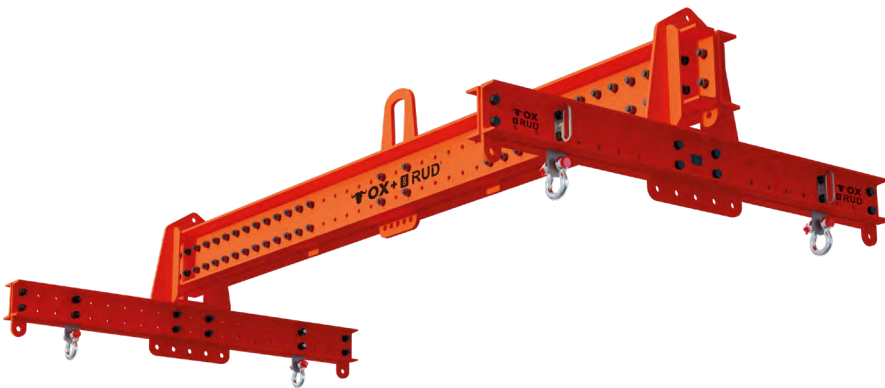

## ADJUSTABLE H-BEAMS

Did you know that our ECO-BEAMS can NOW be turned into an H-SHAPED ECO-BEAM? Multiple configurations, lengths, accessories, and easy to mount, dismantle, inspect them. And more, much more!

## MULTI LUG CONTAINER LIFTING BEAM

The versatile solution to lift not just containers but many other equipments. Why just one lifting beam for one simple purpose? The perfect combination between a container lifting beam and a multi-lug beam.



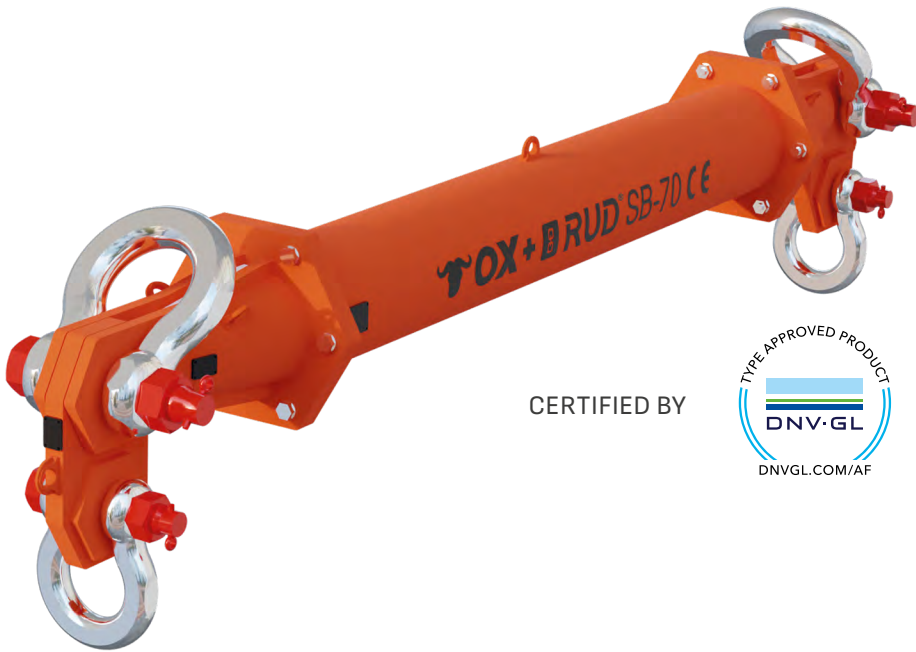

CERTIFIED BY



## SPREADER BEAMS

---

Our spreader beams can lift up whatever you may need. A versatile solution, with modular lengths able to reach up to 36 m spans, and with capacities **from 9 t up to 1.350 t**, all of them certified by DNV-GL.

## SPREADER FRAME

---

Combine your sections of your OX Spreaders to create a frame to lift square or rectangular shaped loads, and reduce your required headroom in the process. Available in many adjustable lengths and **capacities from 9 to 170 t**.

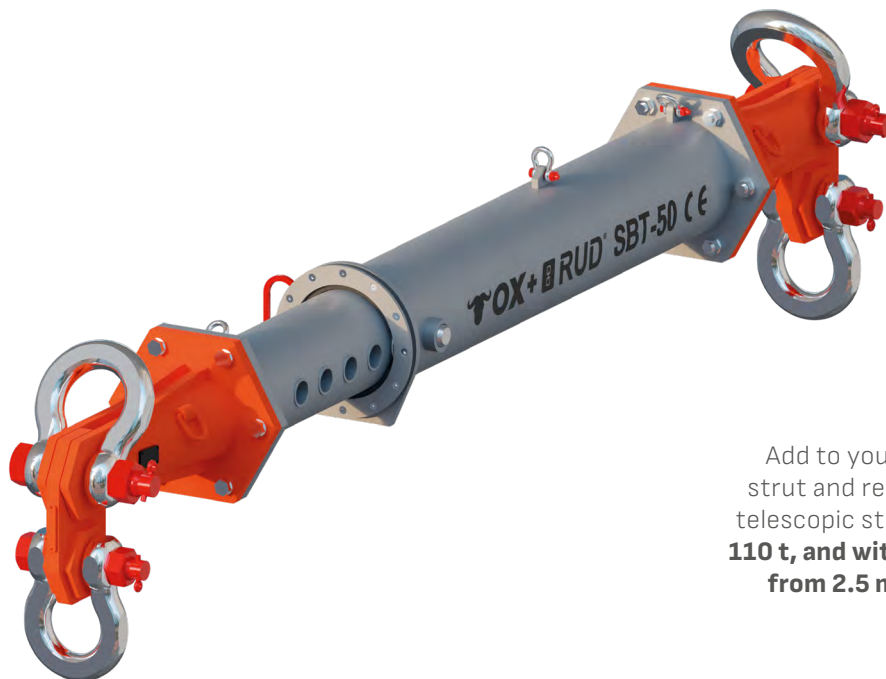

## TELESCOPIC SPREADER BEAMS

---

Add to your OX Spreader Beam the OX SBT telescopic strut and reduce your working time to a minimum! SBT telescopic struts are available with capacities **from 9 to 110 t**, and with lengths **varying from 1.5 m to 2.5 m and from 2.5 m to 4 m**. We can produce bigger versions if needed. Soon other sizes available.

# ADJUSTABLE BEAMS

The ECO BEAM is an economical and fast-supply beam, with NO WELDINGS, easy to inspect and modify.

All beams and accessories are in stock and with quick delivery, **from 1 to 10 t capacity and from 1 to 4 m span.**

There are 2 additional versions for 15 and 20 t and up till 8 m spans.



# ADJUSTABLE H-BEAMS

Convert your Eco-beam into an H Adjustable H-Beam. Capacities from 1 to 20 t and 8000 x 5000mm (length x width). On request.

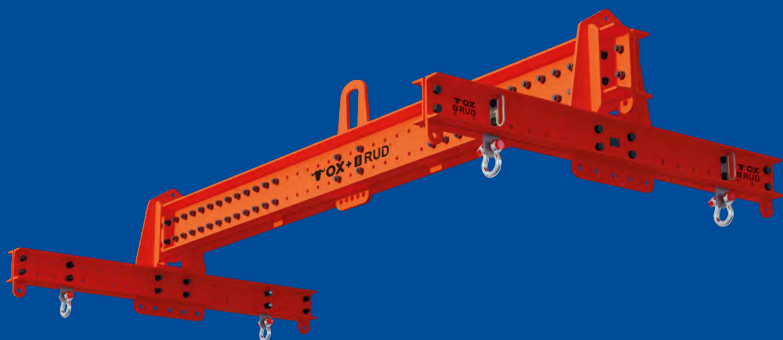

# MULTI LUG BEAMS

Multiple lifting options on top and bottom. Available in STOCK: 10t, 15t, 24t, 34t, 50t and 4 m in length. With forklift pockets for handling, and optional legs. Available ON DEMAND: up to 110 t and up to 10.8 m length.

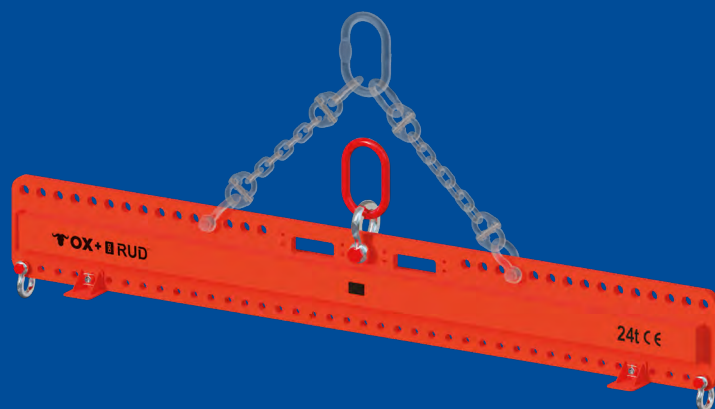

# MULTI LUG CONTAINER LIFTING BEAM

Multi Lug container lifting beams from 10 to 34 t capacities, and total length of 2.5 m. With forklift pockets for handling, and optional legs. Use them for whatever you may need.



# SWIVEL BEAMS

Lifting Beam with motorized electric turning system, to rotate long loads. With top clamping system for 2 or 4 hook cranes, at the bottom it is possible to place eyes or arms for lifting reels, coils or other elements. Possibility to integrate anti-tilting security of displaced COG loads, weighing, and more...

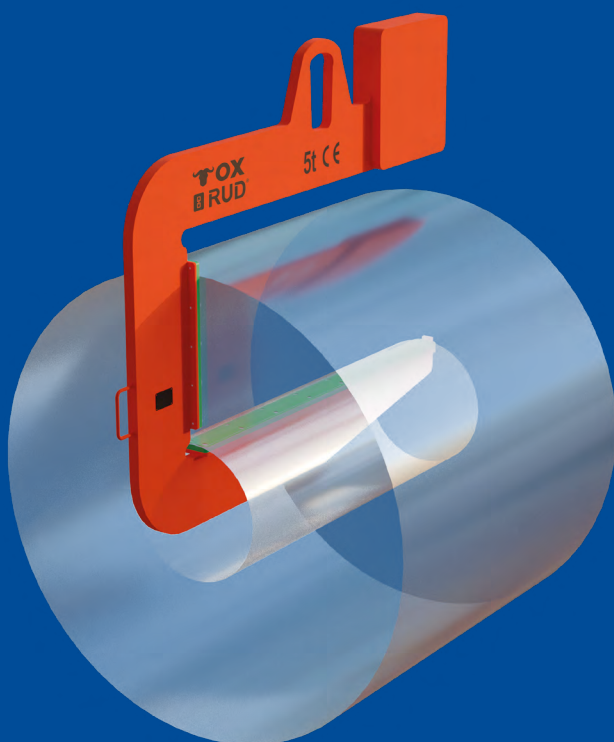

# C-HOOKS

C-Hooks are tools designed to lift coils in a balanced and controlled way. The construction details may vary to adapt to the specific needs of each client.

# TILTING COIL TONG

Tilting C-Hooks to manipulate elements with empty core such as coils and strips of Steel/Aluminum/etc, Rolls of wire rod or hose, paper roll, concrete pipes, etc. They can integrate options such as protections to prevent damaging the material as well as motorized turning, weighing, among others.

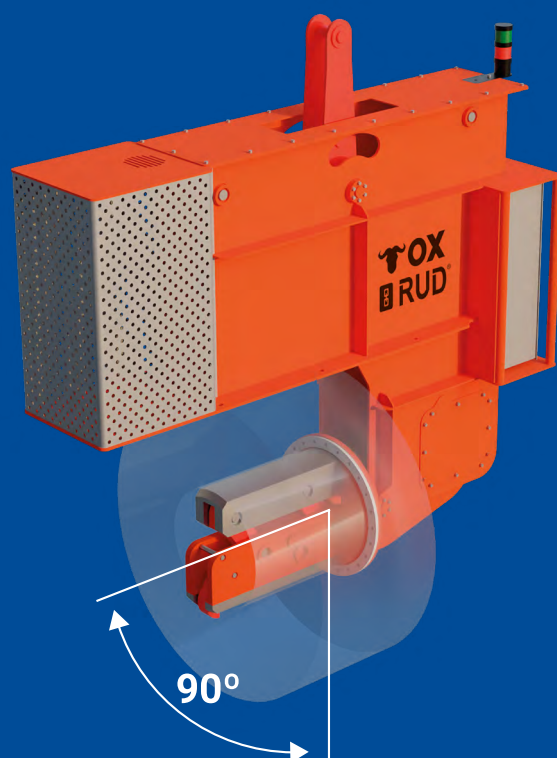

# MINIFORCE30 SELF-PROPELLED TROLLEY

NEW Self-Propelled Trolley with a 30t capacity, **the only one on the market capable of working with single-phase 230v and with Lithium batteries with a touch control screen, Wi-Fi connection and super-reduced height of 180 mm.** Speed of up to 6.5 m/min and autonomy of up to 5 hrs (batteries).  
**With rear trolleys.**



# SELF-PROPELLED TROLLEYS 60-100-150 T

## OX-TBC

Electro-hydraulic Self-Propelled Trolley with lifting cylinder and dual operation: connection to three-phase network or batteries with autonomy of up to 1 h. **60t and 100t capacities.** Speed up to 4 m/min + R/C control.  
**With rear trolleys.**

## OX-ST

Three-phase electric Self-Propelled Trolley  
**Capacities from 60t to 150t.** Speeds up to 5 m/min + R/C control.  
**With rear trolleys.**

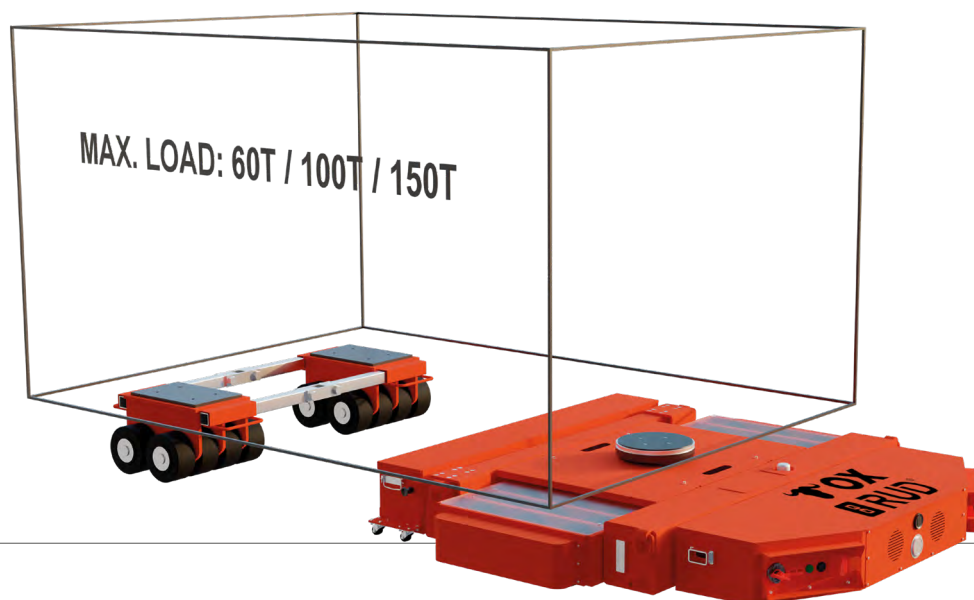

# ROTATING TROLLEY

**4 & 6 t capacity.**



## OX & RUD LIFTING SOLUTIONS, S.L.

OX, as a brand of the CFB Group, was created in 2011, and in 2024 we joined a huge company, RUD Ketten Rieger & Dietz GmbH u. Co. KG., with the mission of offering and bringing to all countries the best solutions for the transport and lifting of loads in a controlled and safe way in any industrial, naval, railway, wind, oil & gas, offshore, automotive, aeronautical and small industries. Now, more than ever, closer to the customer, with distributors and branches on all five continents.

At OX & RUD, engineering, experience and advice are the basis of our quality.

**OX & RUD, now bigger, stronger, better.**

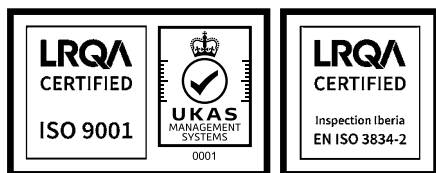

## ISO & DNV CERTIFICATE

We have managed to manufacture and distribute machinery that meets the highest standards.

For this, it is an essential requirement to pass all quality controls, which is why we have the following certifications:

- ISO 9001:2015
- EN ISO 3834-2:2006 (Welding)
- DNV GL-ST-0378 (Standard Spreaders up to 1350t)
- DNV GL-ST-0377 (Standard Spreaders up to 1350t)

OX & RUD is Lloyd Register Quality Assurance certified, in order to comply with all regulations, standards and norms of the European Union.



“Our priority is to provide effective, profitable and safe solutions, to ensure long-term business relationships, through customer satisfaction.”

**Emilio Blasco**  
Founder

**Authorized Distributor**

**YOUR TRUSTED  
PARTNER FOR  
HEAVY LIFTING  
SOLUTIONS**

**OX+ RUD**  
LIFTING SOLUTIONS

Mare de Déu de Núria, 4  
08830 Sant Boi de Llobregat  
Barcelona · Spain

Tel. +34 931 358 928  
info@ox-rud.com  
**ox-rud.com**

**Important note:** All the information contained in this document has been carefully reviewed to ensure its accuracy and reliability. However, it could contain unintentional design or printing errors. For this reason, we recommend that you always confirm any technical data by consulting the official product manuals or by contacting our team of specialists. We are committed to offering the best quality and support for our products and services.